

Micropower Omnipolar Hall Sensor AH3663

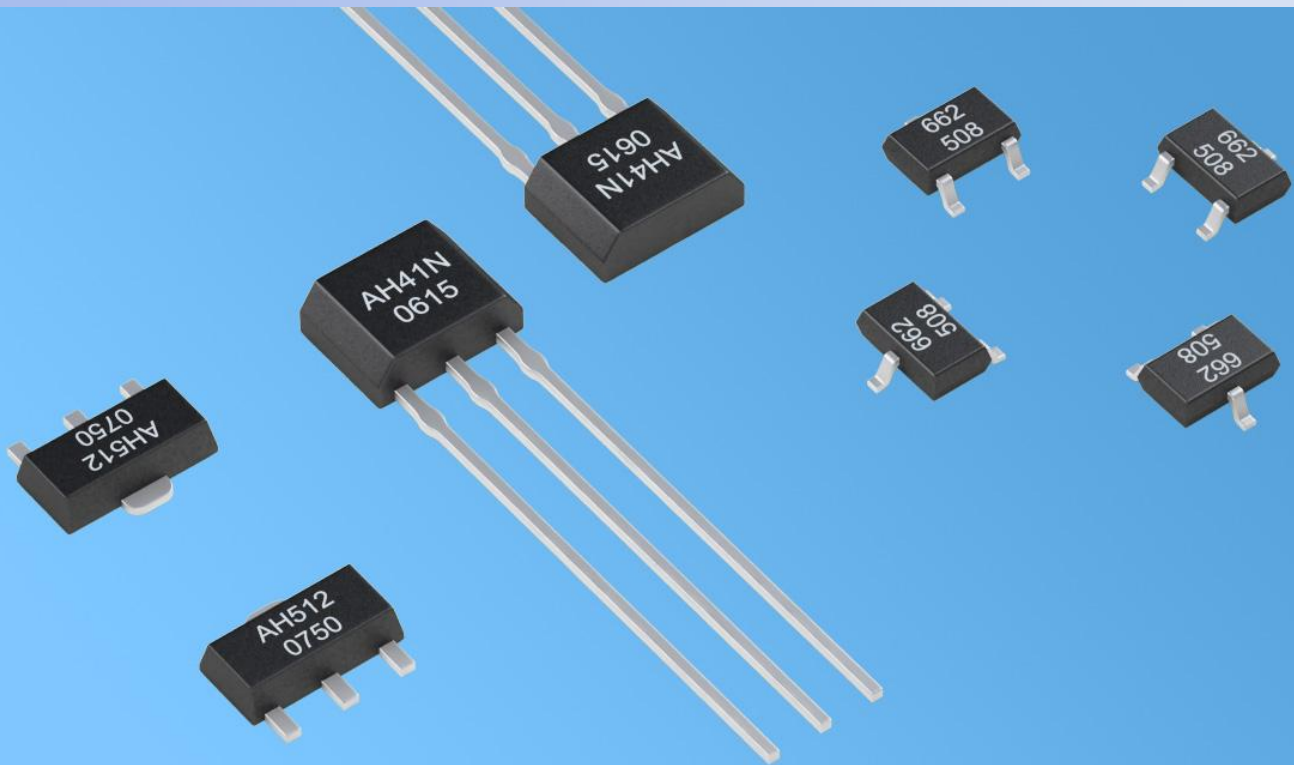

ANINJ

NANJING AH

◆ Features

- Micropower designing.
- Rated supply voltage 2.4 V ~ 5.5 V;
- Omnipolar operating, no “N” or “S” pole in excitation magnetic field, high magnetic sensitivity, highly symmetry in positive and negative magnetic switch point.
- Built-in dynamic imbalance voltage compensation circuit, high temperature stability, Small temperature drift in switch point, resistant to mechanical stress and thermal stress, the power consumption is only 8 μ W when the power supply is 2.75V.
- Products meet the EU RoHS instruction 2011/65 / EU and REACH regulations 1907/2006 / EU requirements



◆ Outline

AH3663 is a kind of high sensitivity omnipolar micropower Hall sensor. The special designing circuit enable the sensor has omnipolar (no “S” or “N” pole) magnetic field excitation function, excellent positive and negative switch symmetry, and bitty average power consumption current. When the magnet (no “S” or “N” pole) is closed to sensor ($|B| \geq |B_{op}|$), the sensor outputs low level; when the magnet is far away from sensor ($|B| \leq |B_{rp}|$), the sensor outputs high level. Stable Hysteresis ($B_{hx} = |B_{opx} - B_{rpx}|$) ensure the sensor's stable switch status, the sensor's magnetic and electric transfer characteristic curve is shown as the figure:

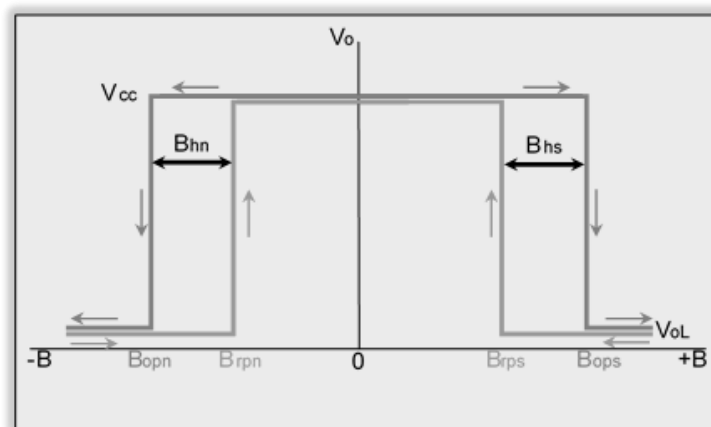

◆Block Diagram

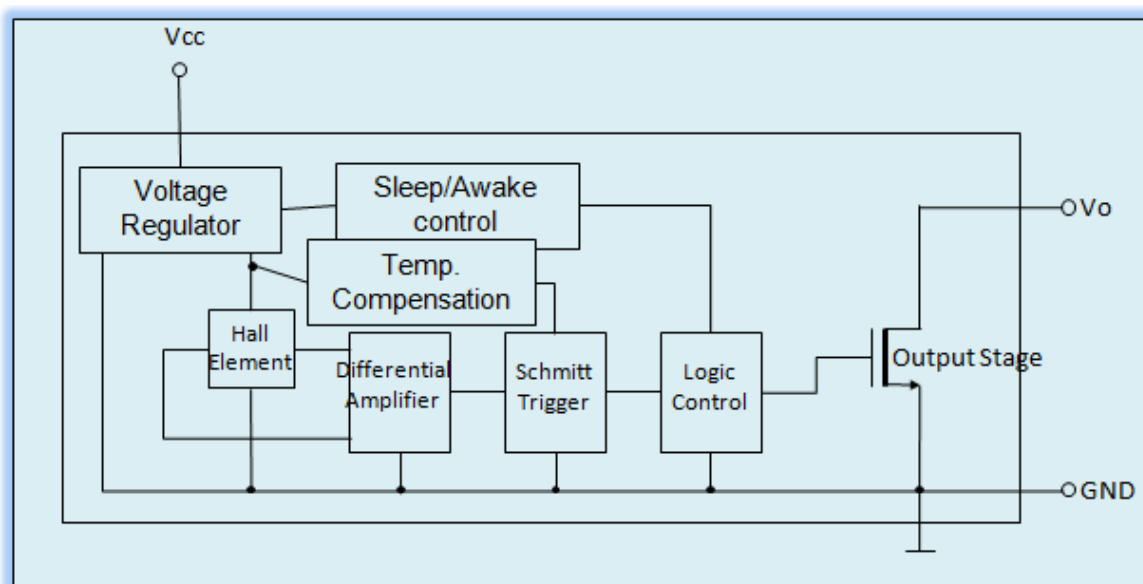

The sensor chip has voltage regulators, Hall-voltage generator, dynamic imbalance voltage compensator, temperature compensator, awake/sleep controller, differential amplifier, Schmitt trigger, logic controller and open collector output driver circuit unit etc.

◆ Sleep Period

The chip has built-in awake/sleep clock control circuit, and its awake/sleep period time is shown in the figure.

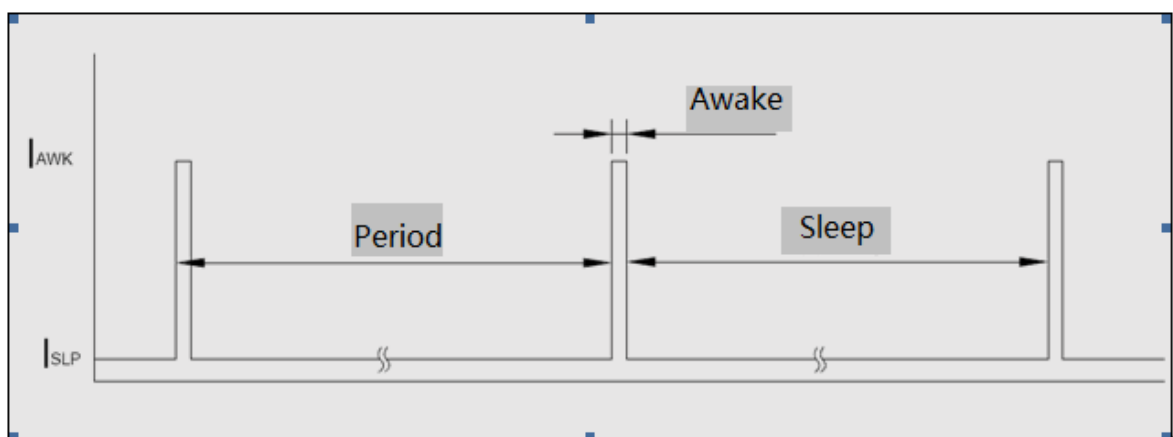

◆Limit Parameter

Parameter	symbol	Min.	Max.	Unit
Storage Temp.	T_s	-55	150	°C
Supply Voltage	V_{CC}	2.4	7	V
Permitted Power consumption	p_d	—	300	mW
Magnetic Induction	B	unlimited	unlimited	mT
Output Current	I_O	—	5	mA

◆Electrostatic Grade

Under human being mode, the Electrostatic compression is large than $\pm 6kV$.

◆ Operating Condition

Parameter	Symbol	Min.	Max.	Unit
Supply Voltage	V_{CC}	2.4	5.5	V
Operating Temp.	T_a	-40	85	°C
Output Current	I_O	—	5	mA

◆ Electrical Characteristic

Parameter	Symbol	Test Condition	Typ.	Max	Unit
Output Low Level	V_{OL}	$V_{CC1}=V_{CC2}=2.75V$, $I_O=1mA$, $B \geq B_{OP}$	0.1	0.25	V
Awake power consumption current	I_{AWK}	Awake, $V_{CC1}=2.75V$, V_o Open circuit	3	5	mA
Sleep power consumption current	I_{SLP}	Sleep, $V_{CC1}=2.75V$, V_o Open circuit	2	4	μA
Average Power Consumption Current	I_{AVG}	$V_{CC1}=2.75V$, V_o Open circuit	6	9	μA
Awake Time	t_{AWV}	$V_{CC1}=4V$, $R_L=200\Omega$, V_o Open circuit	125	150	μs
Period	t_P	$V_{CC1}=4V$, $R_L=200\Omega$, V_o Open circuit	60	80	ms
Duty Factor	f_d	$V_{CC1}=4V$, $R_L=200\Omega$, V_o Open circuit	0.1	—	%

◆Magnetic Characteristic

Test condition : $V_{CC1} = V_{CC2} = 2.75V$, $I_O = 1\text{ mA}$

Parameter	Symbol	Min.	Typ.	Max.
S pole Operate Point	B_{OPS}	—	3	4
N Pole Operate Point	B_{OPN}	- 4	-3	—
S Pole Release Point	B_{RPS}	0.5	1.5	—
N Pole Release Point	B_{RPN}	—	-1.5	- 0.5
Hysteresis $ B_{OPX} - B_{RPX} $	B_{HX}	—	1	2

Note 1: Unit is mT, 1mT=10Gs

Note2: When the “S” Pole of the magnetic field is vertical to the front mark of product, we call the magnetic field $B > 0$.

Package Outline

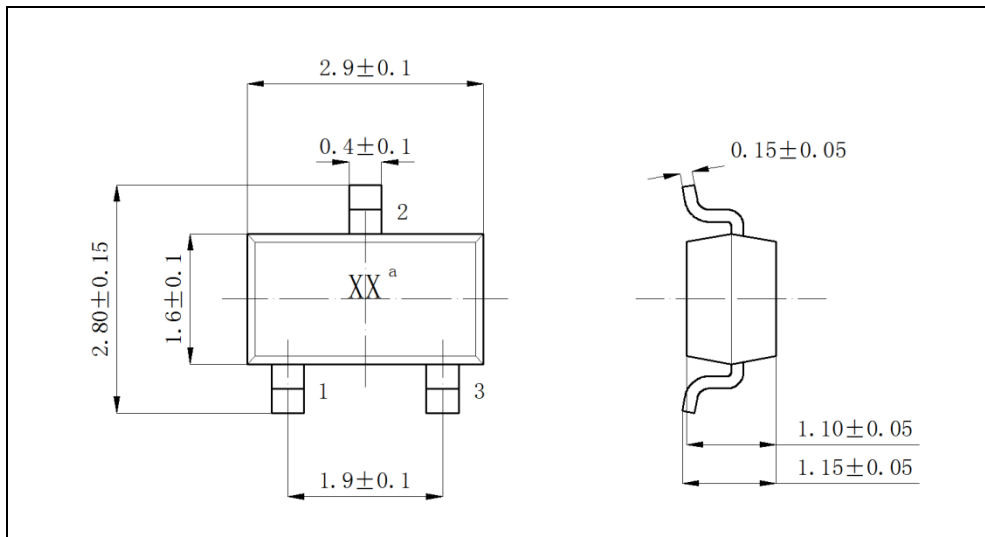

- TO-92UA/TO-92S (UA type) Package figure (Unit: mm)

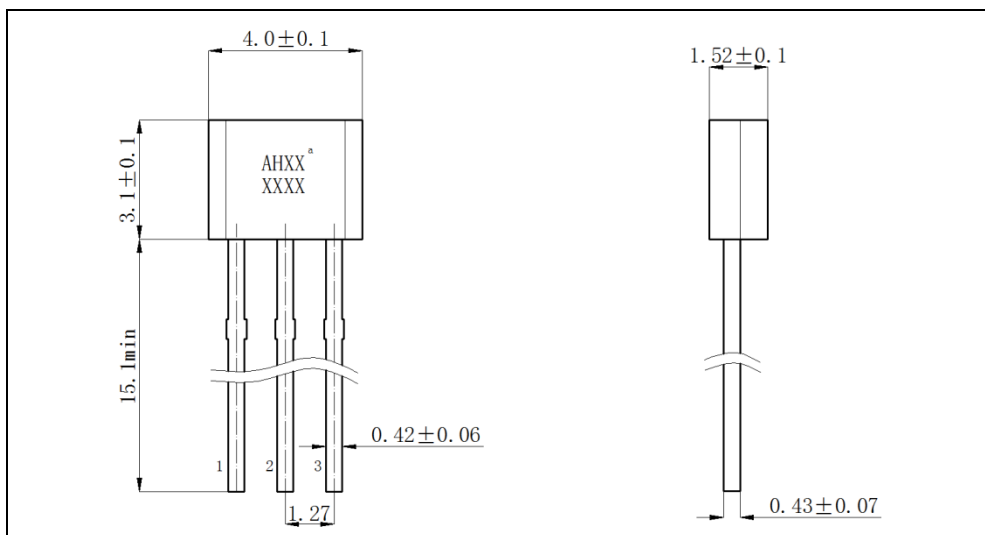

Note: In the above package outline figure, Pin 1: Vcc, Pin2: GND, Pin 3: Output terminal.

● Mark

- Mark “XX” or “AHXX” are abbreviation form of the parts No., the second line”XXXX”means product lot No.